

Install Crankshaft

Plain Bearing Engines

Lubricate crankshaft, tappets, camshaft journals and lobes with engine oil. Assemble timing gear to crankshaft.

1. Install tappets.
2. Install crankshaft into cylinder.
3. Align timing marks and install camshaft, Fig. 1.

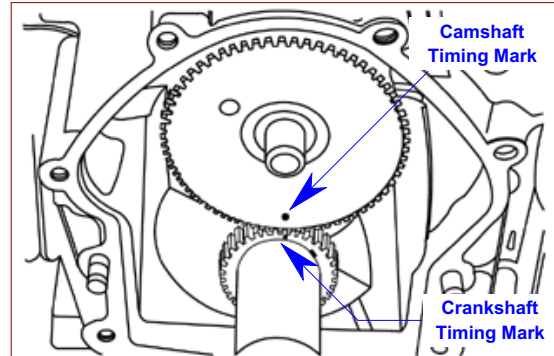

Fig. 1 - Install Crankshaft - Plain Bearing Models

Ball Bearing Engines

Lubricate crankshaft, tappets, camshaft journals and lobes with engine oil.

Note: On ball bearing crankshafts, the gear teeth are covered by the ball bearing. The timing mark is located on the #2 crankpin.

1. Install tappets.
2. Align timing mark on #2 crankpin with timing mark on camshaft and insert both into cylinder.

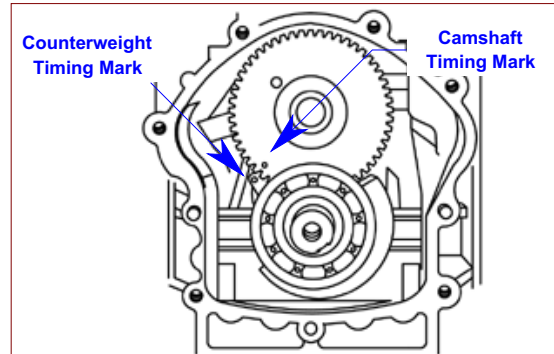

Fig. 2 - Install Crankshaft - Ball Bearing Models